

# AKIRA

makes life better

---

## Air Conditional Service Manual



Большая библиотека технической документации

<https://splitsystema48.ru/instrukcii-po-ekspluatácii-kondicionerov.html>

каталоги, инструкции, сервисные мануалы, схемы.

**Model:**  
**AC-FR30CK**

## CONTENTS

SPECIFICATIONS.....	4
EXPLODED VIEW & PART LIST.....	6
CIRCUIT DIAGRAM.....	10

## SPECIFICATION

Model No.		Description	
Type		Floor standing (cooling only)	
Cooling Capacity (Btu/h)		24000	
Heating Capacity (Btu/h)		N.A	
Rated Input (w)	Cooling	2820	
	Heating	N.A	
PTC Heater Power (W)		N.A	
Moisture Removal (L/H.r)		3.0	
Air Circulation (CMH Max)		1200	
EER for Cooling (Btu/h.W)		8.5	
COP for Heating (W/W)		N.A	
<b>Power supply</b>			
Volt/PPohase/Hz		220-240V/1P/50Hz	
Rated Current (A)	Cooling	13.5	
	Heating	N.A	
	PTC Heater	N.A	
LRA (A)		61	
<b>Noise Level (dB (A))</b>	Indoor Unit	High	50
		Low	40
	Outdoor Unit		58
<b>System</b>			
Refrigerant (g)		R22	
Compressor type		Rotary	
Compressor Model No.		PH420X3CS-8KUC1	
Compressor MFG		TOSHIBA	
Expansion Device		Capillary	
Evaporator		Cooper and aluminum Fin	
Condenser		Cooper and aluminum Fin	
<b>Features</b>			
LCD Wireless Remote Controller		No	
LCD Display		Yes	
Washable Filter		Yes	
24 Hours Timer		Yes	
3 Speed Control		Yes	

Vertical Auto Swing Louver		Yes
Horizontal Auto Swing Louver		No
Sleep Operation		No
Smart Function		Yes
Jet Function		Yes
Electronic Lock		Yes
Auto Restart		Yes
PTC Heater		N.A
<b>Other</b>		
Dimensions WxHxD(mm)	Indoor Unit	540x1765x275
	Outdoor Unit	832x702x380
Net Weight (Kg)	Indoor Unit	45
	Outdoor Unit	58
Packing Dimensions WxHxD(mm)	Indoor Unit	660x1890x420
	Outdoor Unit	980x780x420
Gross Weight (Kg)	Indoor Unit	53
	Outdoor Unit	72
Loading Capacity (40'/40' HC)		72/80
Approvals		CCEE

## EXPLOSIVE VIEW AND PART LIST

### INDOOR UNIT

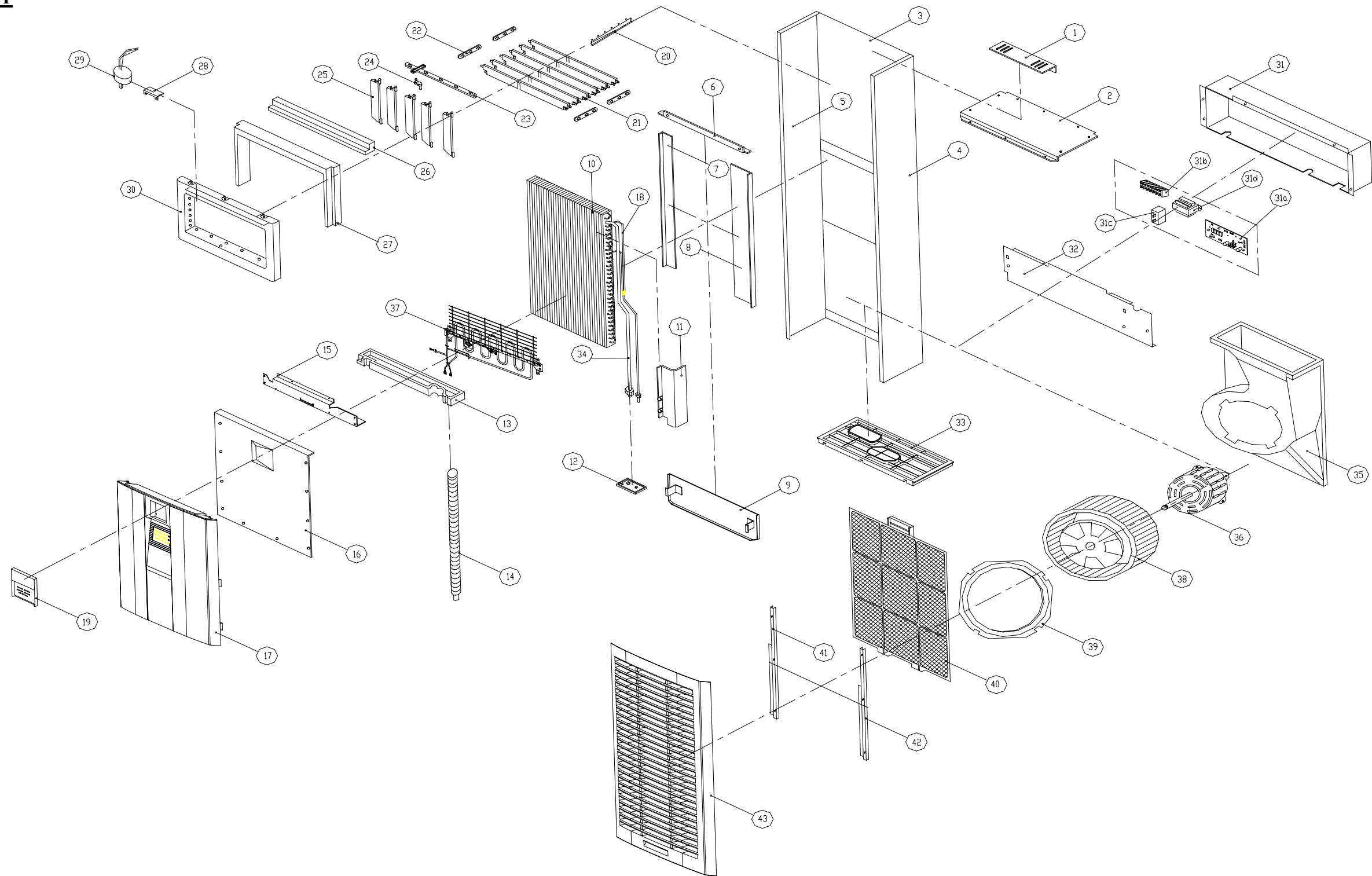

## INDOOR UNIT

No.	DESCRIPTION	Part No.	Q'ty
1	Upper installation shelf	12033011	1
2	Topmost cover	1105376	1
3	Rear cover	11063009	1
4	Right side cover	8100314	1
5	Left side cover	8100313	1
6	Evaporator topmost installation plate	12033017	1
7	Evaporator left installation plate	12033044	1
8	Evaporator right installation plate	12033045	1
9	Evaporator support	12033046	1
10	Evaporator	1301138	1
11	Evaporator baffle	10083002	1
12	Containing water rubber bowl	21063001	1
13	condensate plate assembly	21063006	1
14	Drain hose	21093006	1
15	Middle support	100853	1
16	Adiabatic board	16053005	1
17	Front panel	1006545	1
18	Liquid input pipe assembly	13031950	1
19	Controller assembly	8140190	1
20	Mid pitman	12013019	1
21	Horizontal vane	1201378	6
22	Side pitman	12013018	4
23	Transverse pitman	12013022	1
24	rocker	12013006	1
25	Vertical vane	12013020	5
26	Air outlet bottom foam	1107552	1
27	Air outlet side foam	1107551	1
28	Synchronous motor retainer	11023011	1
29	Synchronous motor A	14023037	1
30	Air outlet	1201377	1
31	Electrical box	10053004	1
31a	Pc board	8140948	1
31b	Terminal 4PUA	150283	1
31c	Fan motor capacitor	14113055	1
31d	Transformer	140561	1
32	Electrical box cover	11053001	1
33	base	1106276	1
34	Evaporator deferent pipe	81303857	1
35	Volute	1007122	1
36	Fan motor	1402282	1
37	Centrifugal fan	1402155	1
38	Air inpour annulus	13031108	1
39	Air filter	12043006	1
40	Filter left retainer	11023012	1
41	Filter right retainer	11023013	1
42	Nether panel	1006547	1

Model No: AC-FR30CK  
 Version 1.0

**OUTDOOR UNIT**

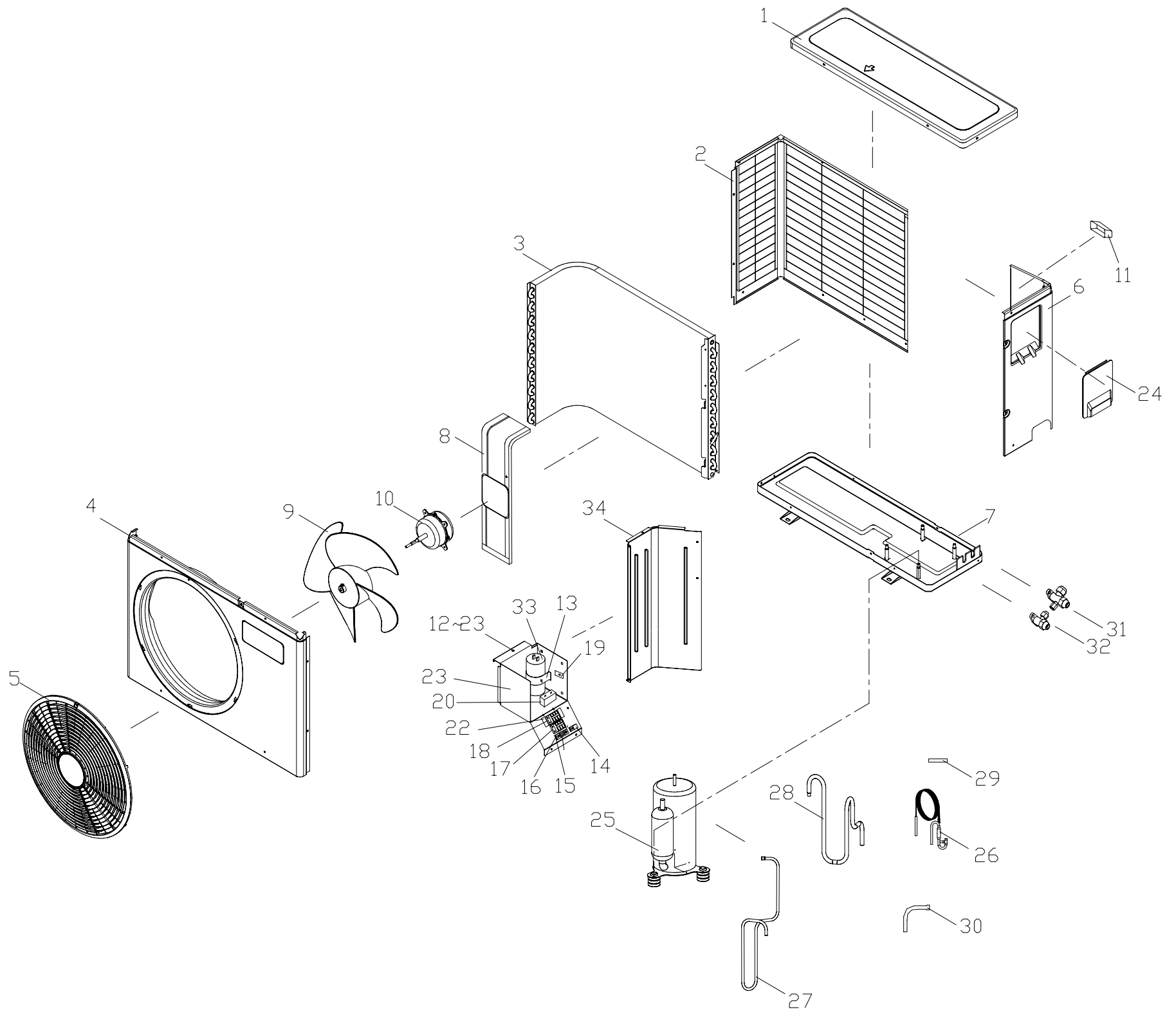



## **OUTDOOR UNIT**

<b>No.</b>	<b>DESCRIPTION</b>	<b>Part No.</b>	<b>Q'ty</b>
1	Upper cover	810132	1
2	Rear cover	810091	1
3	Condenser	813024	1
4	Front cover	810135	1
5	Fan guard	821071	1
6	Right side cover	10033032	1
7	Base	810022	1
8	Motor support	811021	1
9	Propeller fan	140239	1
10	Fan motor	1402370	1
11	Carry cover	21093063	1
12	Electrical assembly	814019	1
13	Capacitor clamp	12033022	1
14	Wire clamp	1203234	1
15	Power wire nether Clamp	110963	1
16	Power wire upper Clamp	1109147	1
17	Terminal 3P1	150289	1
18	Terminal 4P2	15023004(A)	1
19	Terminal 2U	150217	1
20	Fan motor capacitor	14113058	1
21	AC contactor	1411941	1
22	Wire fixer	1109186	1
23	Electrical box	10053005	1
24	Terminal cover	2109236	1
25	Compressor (GD Toshiba)	1304325	1
26	Capillary assembly	81303825	1
27	Vent-pipe	81303540	1
28	Suction pipe	81303541	1
29	Condenser input pipe	13033323	1
30	Transition pipe	13033038	1
31	3-valve assembly 16a	8130914	1
32	2-way valve 10	8130918	1
33	Compressor capacitor	14113044	1
34	Clapboard	12033035	1

## CIRCUIT DIAGRAM

### Indoor unit

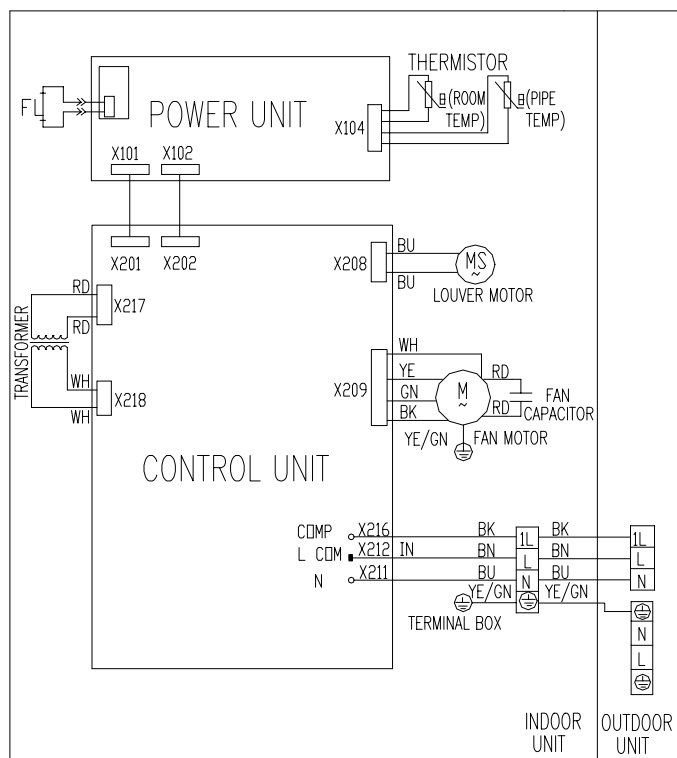

**Outdoor unit**

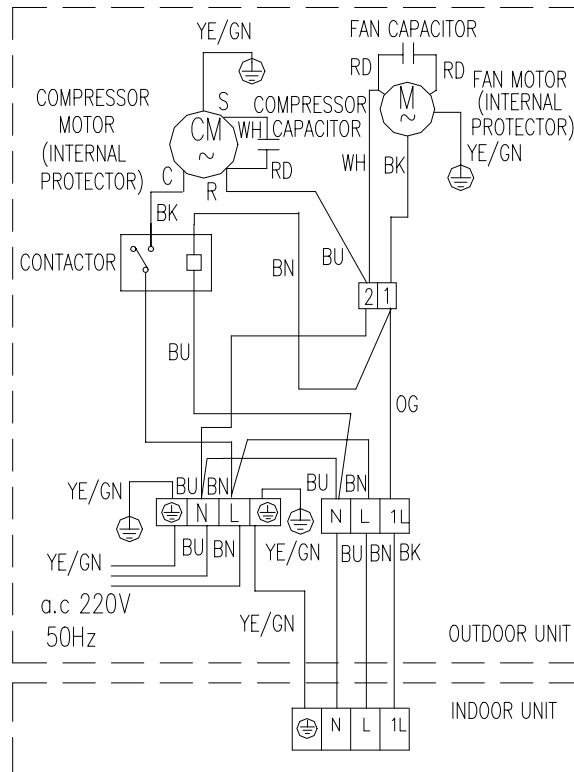



**Большая библиотека технической документации**  
<https://splitsystema48.ru/instrukcii-po-ekspluatacii-kondicionerov.html>  
**каталоги, инструкции, сервисные мануалы, схемы.**